

MULTI-THERM automatic double regulating valve, FPT, 111 °F - 129 °F, figure 154 04



Product Features

- for hydraulic balancing of hot water return systems (PWH-C), supports thermal disinfection
- wetted metal parts made from dezincification-free, corrosion-resistant and lead-free gunmetal, resistant against aggressive water
- isolating unit with temperature sensor pocket
- PTFE seat gasket
- thermostatic regulating unit
- female pipe thread
- with plugged Drain Port
- free from dead spots

Standards and Approvals

- NSF/ANSI 61 & NSF/ANSI 372
- IAPMO/IGC 302

Technical Data

- control range 111 °F - 129 °F
- pressure rating PN 16
- max. operating temperature 194 °F

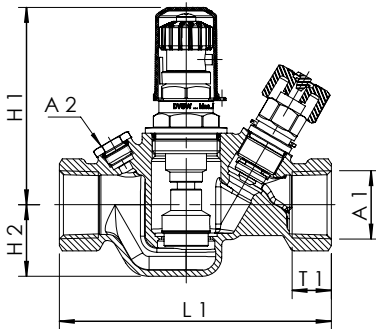

part no.	A1	A2	H1 in	H2 in	L1 in
1540401500	FPT 1/2	G 1/4	3.3	1.1	4.3
1540402000	FPT 3/4	G 1/4	3.3	1.3	4.8
1540402500	FPT 1	G 1/4	3.8	1.4	5.2